



Fakulteta za gradbeništvo,
prometno inženirstvo in arhitekturo
Študentski svet



HowStrongIsTheBridge



AJKTM 2018

»HOW STRONG IS THE BRIDGE?! 2018«

9th international spaghetti bridge competition

RULES AND REGULATIONS



Table of contents

1. MISSION	2	3.2. Tools	12
2. General	2	3.3. Construction process	13
2.1. Organizer	2	3.3.1. Before the construction starts	13
2.2. Date, place and fee	2	3.3.2. During construction	13
2.3. Participants	3	3.3.3. After construction	13
2.4. Team	3	3.4. Load test	13
2.5. Rules	3	3.5. Safety	14
3. PROBLEM STATEMENT	3	3.6. Objections	14
3.1. Restrictions	3	4 SCORING SYSTEM	15
3.1.1. General restrictions	3	4.1. General	15
3.1.2. Materials provided by organizer	4	4.2. Bearing capacity category	15
3.1.3. Geometry of the bridge	5	4.3. Design category	15
3.1.4. Supports	5	5 ANNOUNCING THE WINNERS	17
3.1.5. Mass of the bridge	7	6 PENALTIES	17
3.1.6. Spaghetti gluing	7		



1

MISSION

Our mission is to create an opportunity for students from all over the world to come together and compare each other's engineering skills in a competitive yet friendly atmosphere. »How Strong Is The Bridge?!« gives students a chance to design and build their own spaghetti bridge which has to meet certain criteria (see chapter 3). In seek of the most optimal solution, students must be innovative, inventive and precise. Students have to put the knowledge obtained in school into practical use in the best possible way. We hope »How Strong Is The Bridge?!« will contribute to the expansion and exchange of diverse engineering knowledge among students.

2

GENERAL

2.1. Organizer

- [1] AJKTM 2018 (»How Strong Is The Bridge?! 2018«) is organized by Student Council of Faculty of Civil Engineering, Transportation Engineering and Architecture UM and Students' Association of Faculty of Civil Engineering, Transportation Engineering and Architecture.

2.2. Date, place and participation fee

- [1] AJKTM 2018 will be held on 9-11 May 2018 in Borut Pečenko hall at University of Maribor, Faculty of Civil Engineering, Transportation Engineering and Architecture (Smetanova ulica 17, Maribor, Slovenia). This includes competition days and social events.
- [2] Detailed schedule will be sent via e-mail before the competition.
- [3] Participation fee for AJKTM 2018 is 165 EUR per team.



2.3. Participants

- [1] The participants of the contest are all students and have to be declared as such in the application form.
- [2] Only students studying on the Bachelor's or Master's level are allowed to attend the competition.
- [3] A participant can only be involved in one team.

2.4. Team

- [1] Team consist of 3 students from the same university.
- [2] Teams must choose a captain among the 3 members.

2.5. Rules

- [1] The participants of the competition have to follow this document (which contains the rules and regulations of the competition) from the moment of sending an application form until the end of the competition.
- [2] The rules and regulations are posted on the official competition website ajktm.fg.um.si.
- [3] The organizer has a right to make minor changes in the rules and regulations in the future, if problems/issues concerning the rules and regulations appear.

3

PROBLEM STATEMENT

3.1. Restrictions

3.1.1. General restrictions

- [1] The bridge consists of structural elements (hereafter »elements«).
- [2] The number of elements is unlimited.
- [3] Organizer will provide all the materials needed for building a bridge.
- [4] Elements can only be made from materials provided by the organizer.
- [5] All elements must be stable and safe after the assembly phase.

3.1.2. Materials provided by the organizer

- [1] Barilla n.7 spaghetti.
- [2] Hot glue Pattex.
- [3] Elements for load transmission, wooden sticks $\Phi = 18$ mm.
- [4] Plastic supports.
- [5] Stress-strain curves of spaghetti and glue are shown on graph 1 and 2.

GRAPH 1 – Spaghetti stress-strain curve.

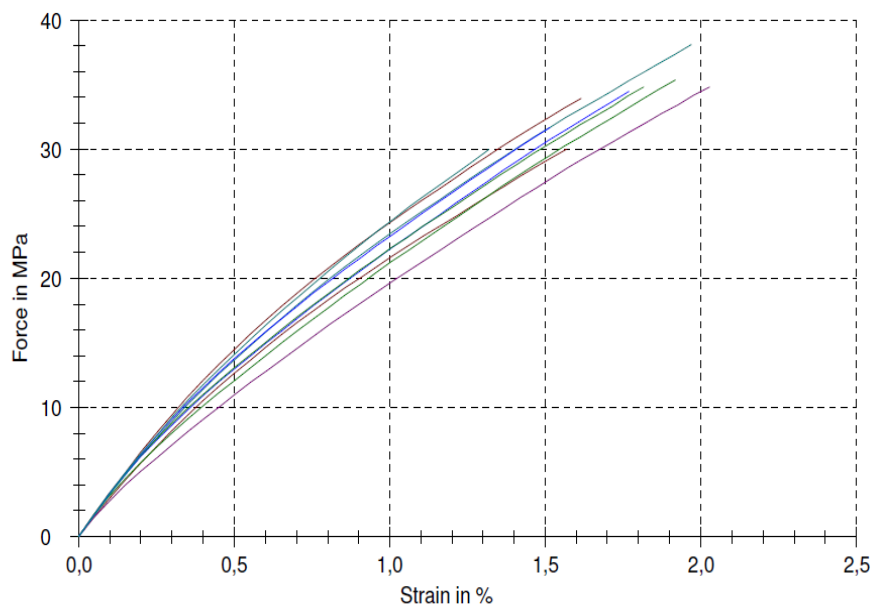

GRAPH 2 – Glue stress-strain curve.

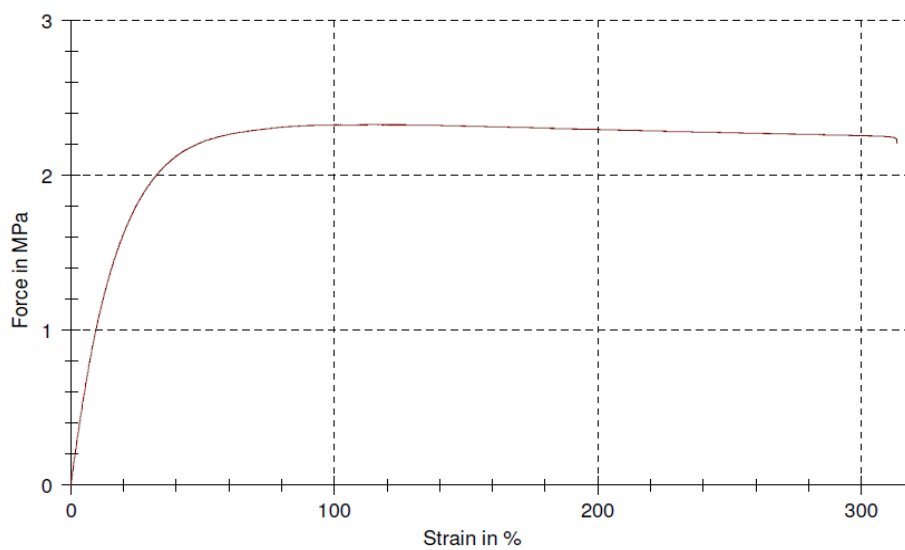



3.1.3. Geometry of the bridge

- [1] Bridge axis is the shortest distance between the supports. The axis is situated on the top of the supports and represents the bridge deck.
- [2] The span of the bridge must be 1000 mm (+/-0 mm construction tolerance). Span is measured as shown in figure 1.
- [3] Width of the bridge should be max 200 mm. Width is measured as shown on figure 1.
- [4] The highest point of the bridge should be max 300 mm from bridge axis. Height is measured as shown on figure 1.
- [5] Building below bridge axis is not allowed.
- [6] A 100x50 mm box must be able to cross the bridge. Position of the box is shown on figure 1.
- [7] Wooden sticks must be installed on the loading points as shown on figure 1.
- [8] In case of any violation of these restrictions (1-7) penalty 1 ($0.63 \cdot x^{1.29}$ points) will apply for each violation.

3.1.4. Supports

- [1] Supports are the only points (axis), where bridge can be in touch with the loading machine.
- [2] Supports are fixed as follows (see figure 1):

Displacement in x	=	fixed
Displacement in y	=	not fixed
Displacement in z	=	fixed*
Rotation around x	=	fixed
Rotation around y	=	not fixed
Rotation around z	=	fixed

*downward only

FIGURE 1 – Restrictions on the geometry of the bridge.

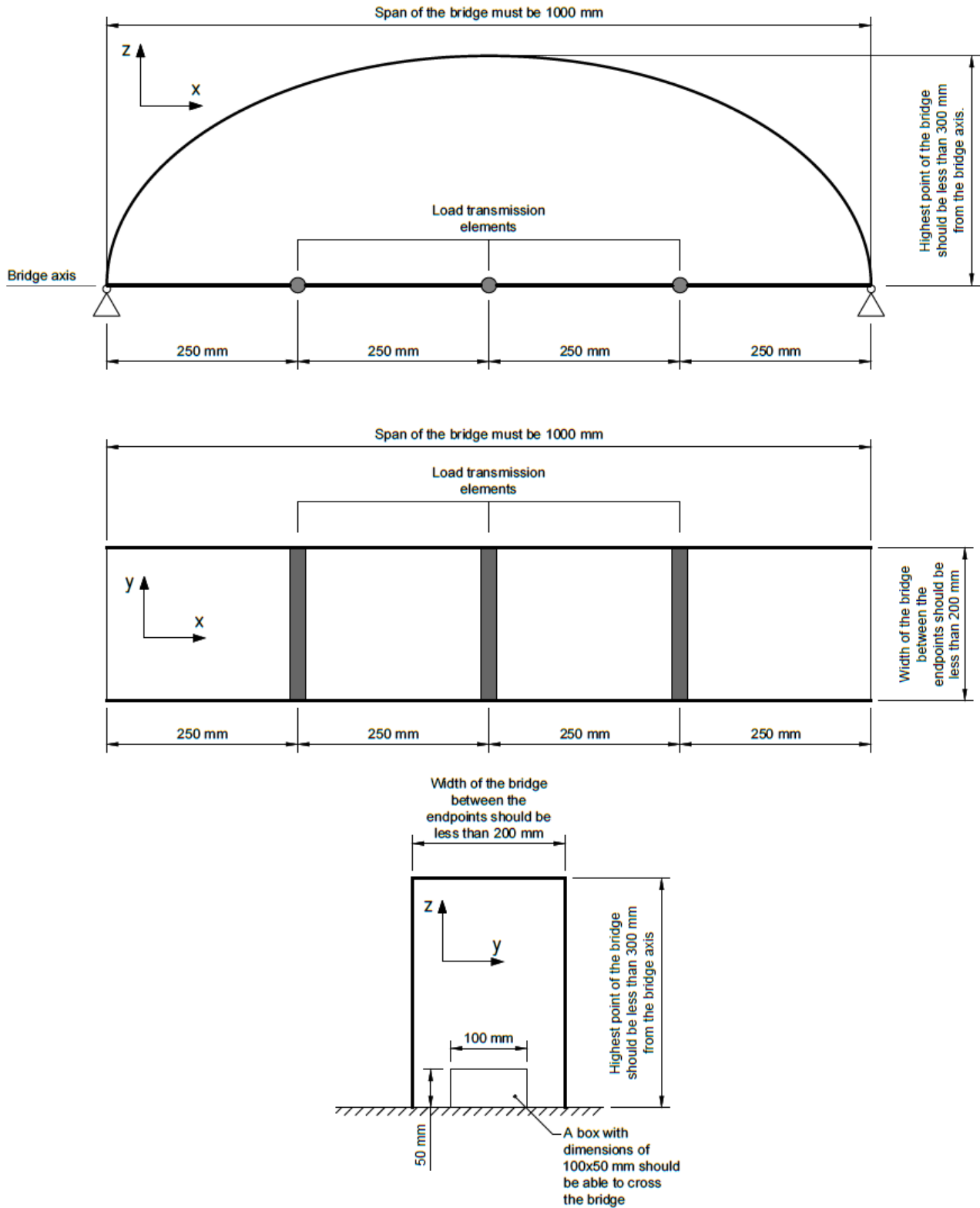



3.1.5. Mass of the bridge

- [1] Mass of the bridge should be less than 1400 g (+15g tolerance). Mass of the bridge is sum of all implemented materials, together with supports and wooden sticks.
- [2] In case of any violation of restriction (1) penalty 2 ($0.069 * x^{1.70}$ points) will apply.

3.1.6. Spaghetti gluing

- [1] Gluing is permitted on the edges of spaghetti only.
- [2] The shortest length between glued joints is 30 mm (-1 mm tolerance).
- [3] Width of glue applied is max 10 mm (+1mm tolerance). Spaghetti should not be glued together into elements longitudinally.
- [4] Only use of tools stated in section 3.2. is permitted.
- [5] In case of any violations of these restrictions (1) or (4) penalty 6 (disqualification) will apply.
- [6] In case of any violations of these restrictions (2) or (3) penalty 3 ($2.5 * x^{1.30}$ points) will apply for each violation.
- [7] The restrictions on spaghetti gluing are presented on figure 2.

FIGURE 2 – Restrictions on spaghetti gluing.

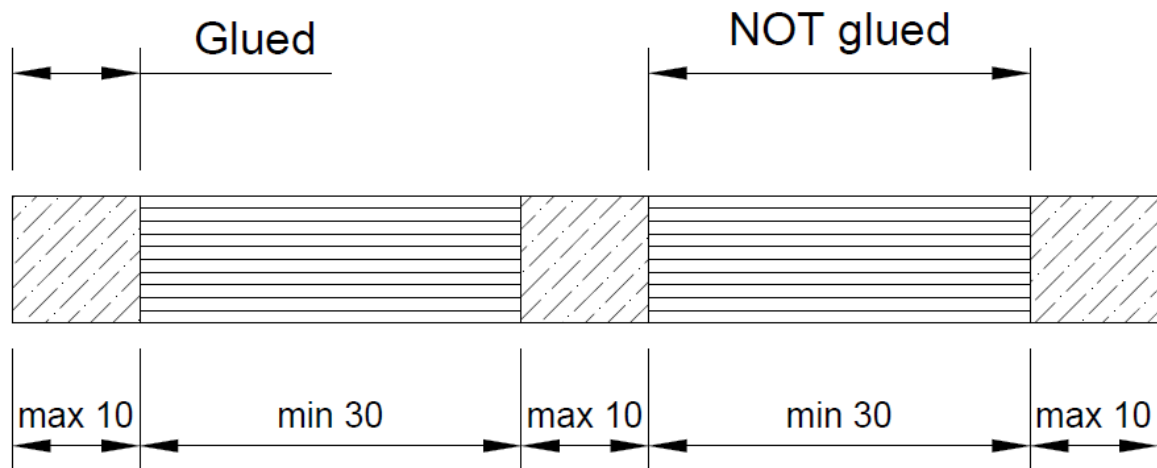

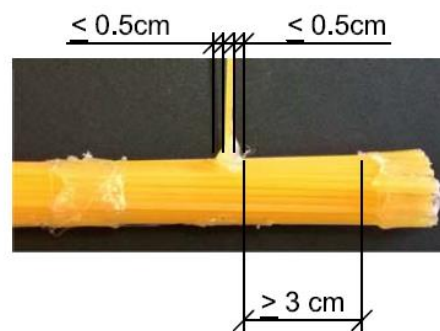
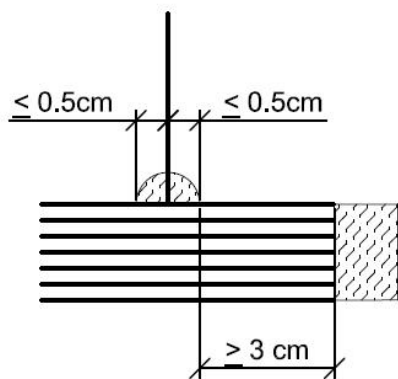
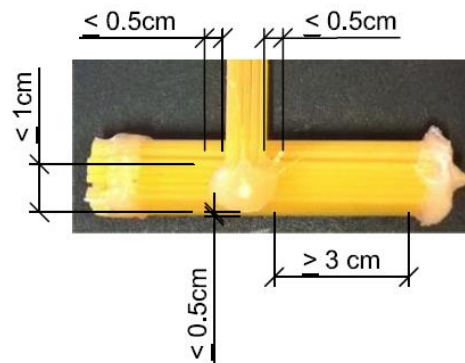
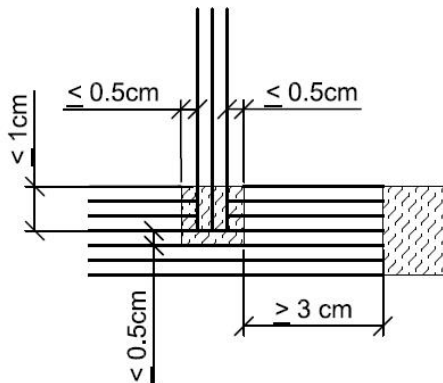
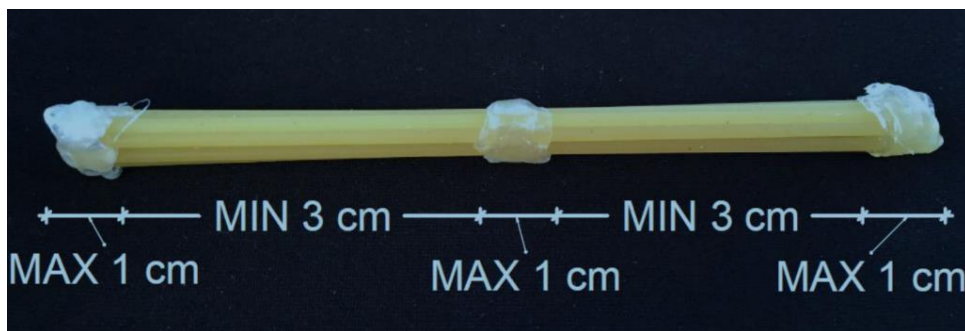
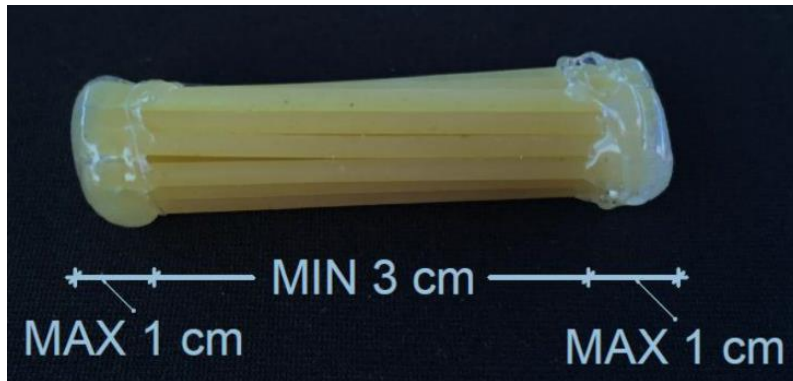

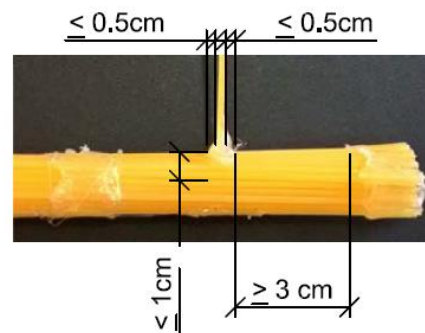
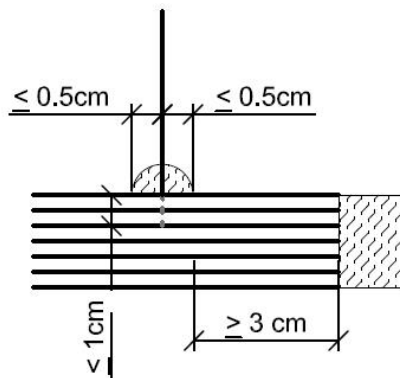
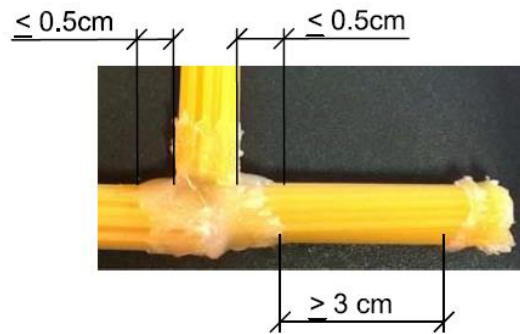
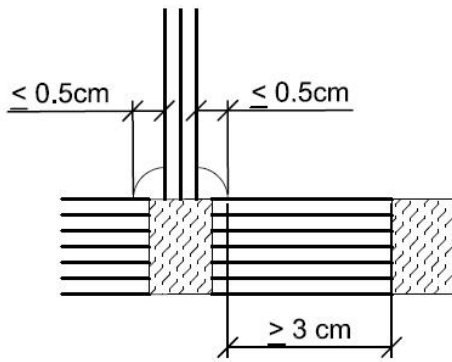
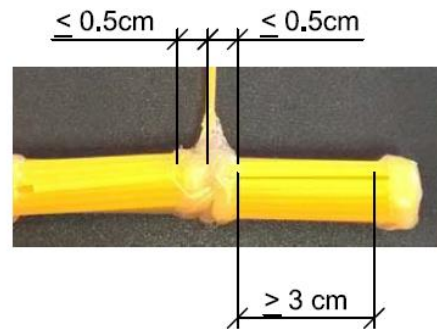
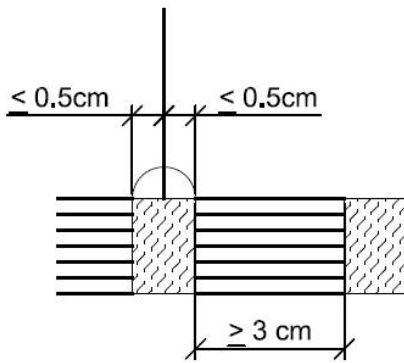
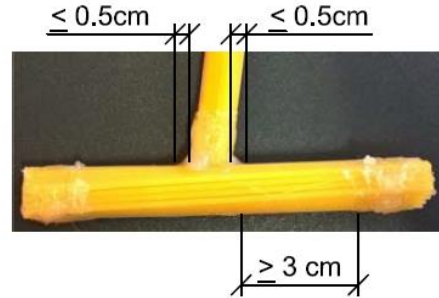
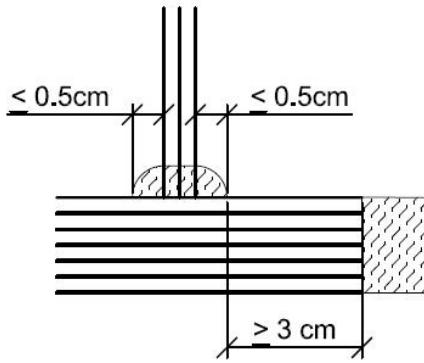

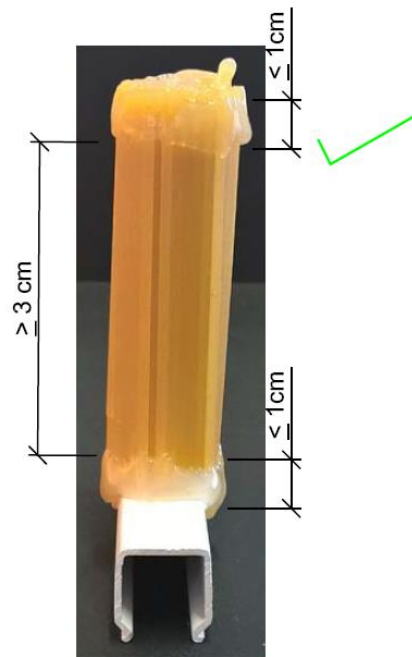
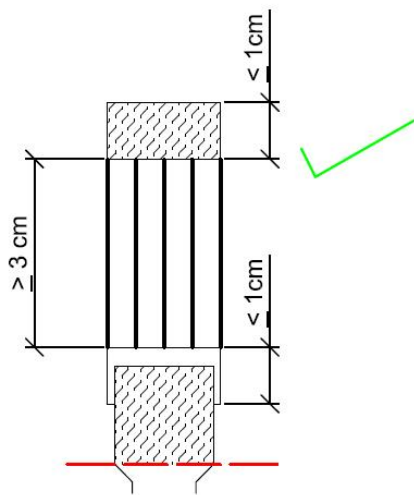
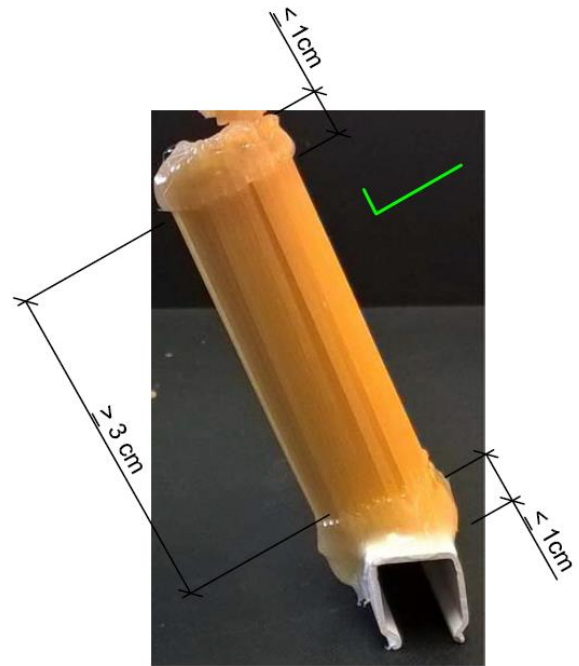
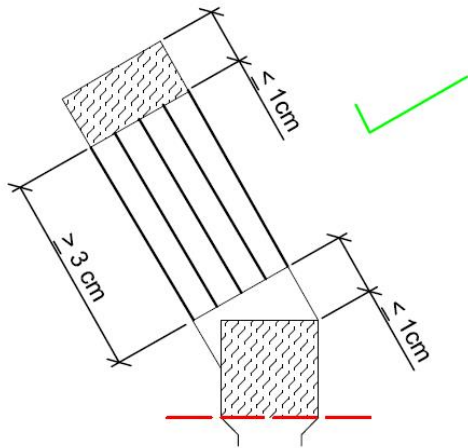

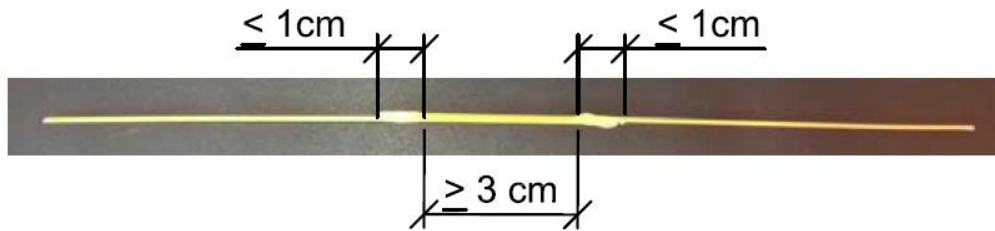
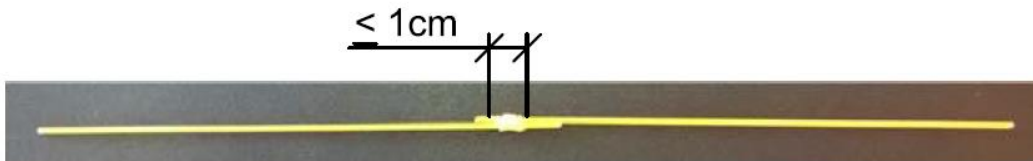
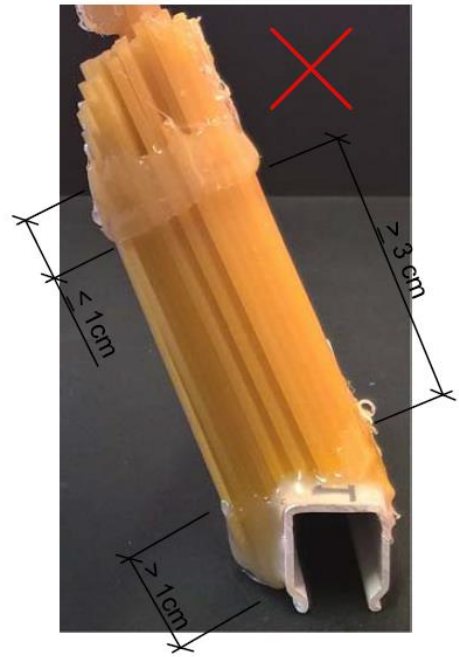
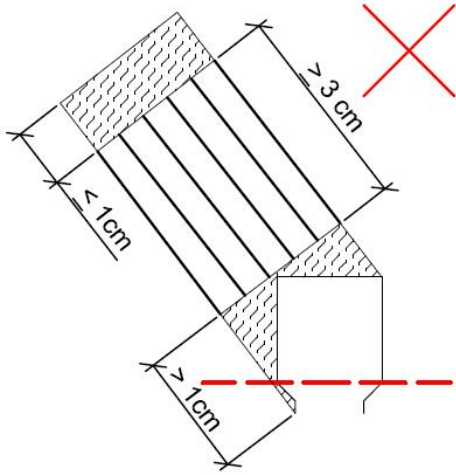

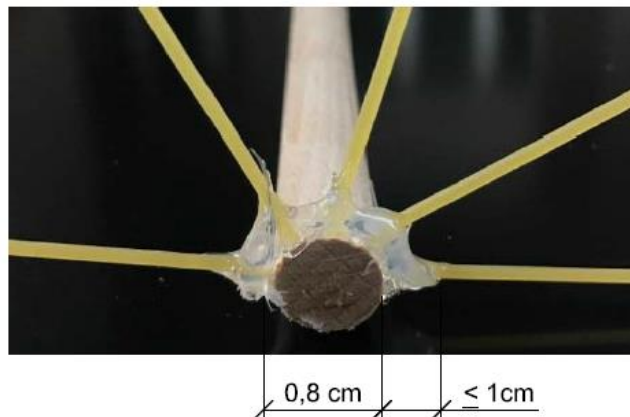
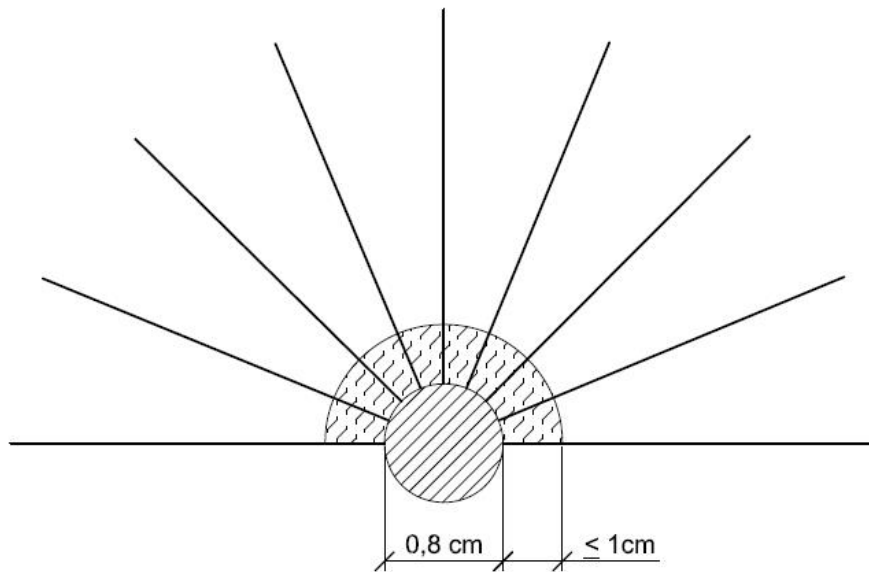

3.2. Tools

- [1] The use of any hand tools is allowed.
- [2] The use of any electric, pneumatic or any other tools that converts mechanical energy into work is not allowed. Only use of electric hot glue guns is allowed.
- [3] Organizers provides following tools:
 - electric hot glue guns
 - knives
 - rubber bands
- [4] The use of all other hand tools, not contrary to restriction (2), is allowed (competitors shall provide such tools themselves). The use of computer software and calculators is allowed.



- [5] In case of any violation of these restrictions (1) or (2) penalty 6 (disqualification) will apply.

3.3. Construction process

3.3.1. Before the construction starts

- [1] For design and planning, teams can use any software.
- [2] Teams can prepare drawings, plans or other assistance for building, if they do not conflict with section 3.2.

3.3.2. During construction

- [1] It is allowed to support the bridge or a single element.
- [2] Temporary supports must be stable and must not pose a threat to competitors.
- [3] It is forbidden to throw tools, elements or other items that could cause personal injuries.
- [4] Participants must not hinder other participant at their work.
- [5] In case that the organizer detects any violation of these restrictions (2-4), members of the team will be immediately informed. If members of the team continue with violation of restrictions (2-4) penalty 5 (50 points) will apply.

3.3.3. After construction

- [1] All temporary supports should be removed.
- [2] The team has to put the constructed bridge to a specific place.
- [3] Each bridge will be inspected by the rules committee. During the inspection of the bridge, the team captain may also be present.

3.4. Load test

- [1] Before loading begins, the bridge is fixed to a special steel frame. This frame is used to simulate the support conditions.
- [2] The hooks of the loading machine, which are transferring the load on the bridge, are attached to the wooden sticks.
- [3] The load is gradually increasing until the final collapse of the bridge. Bearing capacity of the bridge is the maximum load on the bridge before it collapses.
- [4] The load test is completed after the bridge has been collapsed.
- [5] The load test may be terminated in case that the loading machine reaches its maximum deflection and the bridge failure has not yet been achieved. The load test may also be terminated in case where further loading could pose a risk to people.
- [6] Static system of load test is shown on figure 3.

FIGURE 3 – Static system of load test.

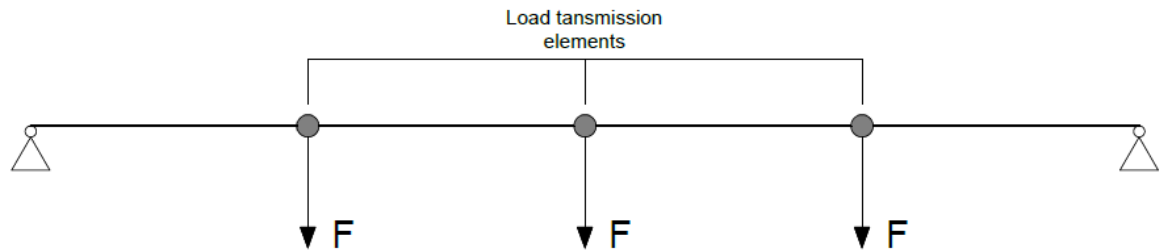

3.5. Safety

- [1] Safety has the highest priority during competition.
- [2] In case of a serious violation of any safety precautions, the team will be disqualified immediately.
- [3] In case of smaller violation of safety precautions, penalty 4 (25 points) will apply.
- [4] Special safety equipment is not required.
- [5] Hot glue and the tip of glue gun can cause burns. Competitors should be particularly careful when gluing and handling glue gun.
- [6] Bridges that are clearly damaged or unstable shall not be accepted for load testing.
- [7] During the competition, any activity shall be halted if a judge considers it to be hazardous..

3.6. Objections

- [1] Objections can be made about any violation of the rules.
- [2] Each team can make a maximum of three objections during competition.
- [3] Teams can voice their objections orally to the judge or rules committee. Only team captain can voice the objection.



4

SCORING SYSTEM

4.1. General

- [1] All teams compete in bearing capacity category and design category.
- [2] Students teams and high schoolers teams compete separately in bearing capacity category.
- [3] Students teams and high schoolers teams compete together in design category.

4.2. Bearing capacity category

- [1] The teams shall be ranked according to the results after the load test and after deductions for derogation from the rules and regulations.
- [2] In case that two or more teams achieve the same result after all deductions have been made, the ranking of the teams is determined by the mass of the bridge. Higher placed is the team with the lowest mass of the bridge.

4.3. Design category

- [1] The concept, creativity, uniqueness and aesthetics are evaluated.
- [2] The votes are awarded by the expert commission and the audience. The expert commission is comprised of renowned designers of bridges from Slovenia, architects and professors from the faculty of the host.
- [3] Each member of the expert commission can give a vote of up to ten bridges.
- [4] Each member of the audience can give a vote of up to three bridges.
- [5] The points are awarded separately by the number of votes of the expert commission and the audience. Ranking points are shown in table 1 and 2.
- [6] The first place is won by the team with highest score. The team can score up to 200 points.
- [7] In case that two or more teams achieve the same result after all deductions have been made, The ranking of the teams is determined by the bearing capacity of the bridge. Higher placed is the team with greater bearing capacity.
- [8] In case that the team does not receive a single vote, it will score 0 points.



TABLE 1 – Scoring system by votes of experts commission.

1 st place	=	100	16 th place	=	20
2 nd place	=	80	17 th place	=	18
3 rd place	=	60	18 th place	=	16
4 th place	=	55	19 th place	=	14
5 th place	=	51	20 th place	=	12
6 th place	=	47	21 st place	=	10
7 th place	=	43	22 nd place	=	9
8 th place	=	40	23 rd place	=	8
9 th place	=	37	24 th place	=	7
10 th place	=	34	25 th place	=	6
11 th place	=	31	26 th place	=	5
12 th place	=	28	27 th place	=	4
13 th place	=	26	28 th place	=	3
14 th place	=	24	29 th place	=	2
15 th place	=	22	30 th place	=	1

TABLE 2 – Scoring system by votes of audience.

1 st place	=	100	16 th place	=	15
2 nd place	=	80	17 th place	=	14
3 rd place	=	60	18 th place	=	13
4 th place	=	50	19 th place	=	12
5 th place	=	45	20 th place	=	11
6 th place	=	40	21 st place	=	10
7 th place	=	36	22 nd place	=	9
8 th place	=	32	23 rd place	=	8
9 th place	=	29	24 th place	=	7
10 th place	=	26	25 th place	=	6
11 th place	=	24	26 th place	=	5
12 th place	=	22	27 th place	=	4
13 th place	=	20	28 th place	=	3
14 th place	=	18	29 th place	=	2
15 th place	=	16	30 th place	=	1



5

ANNOUNCING THE WINNERS

On the 3rd day of the competition, winners will be announced in the following categories:

- Bearing capacity (first, second and third place)
- Design (First place)

The winning teams will receive a considerable monetary prize.

6

PENALTIES

- [1] 5 penalty points means deduction (-) 1 kg in bearing capacity category.
- [2] 2 penalty points means deduction (-) 1 point in design category.
- [3] In case that the team collects more than 50 penalty points, disqualification is followed without reimbursement of the participation fee.

Penalty 1	$0.63 \cdot x^{1.29}$ points x = violation in mm	Applies to violations of the restrictions on the geometry of the bridge (3.1.3).
Penalty 2	$0.069 \cdot x^{1.70}$ points x = violation in g	Applies to violation of the restrictions on the mass of the bridge (3.1.5).
Penalty 3	$2.5 \cdot x^{1.30}$ points x = violation in mm	Applies to violation of the restrictions on spaghetti gluing (3.1.6).
Penalty 4	25 points	Applies to violation of safety restrictions (3.5).
Penalty 5	50 points	Penalty refers to the construction process (3.3).
Penalty 6	Disqualification	Penalty refers to unauthorized use of tools (3.2).